



Mini VRF Cooling Only System

User Manual

VEC027N432U
VEC034N432U
VEC042N432U
VEC048N432U
VEC055N432U
VEC060N432U

Thank you for selecting LENNOX air conditioners. Please read this manual carefully before operation and keep it for further reference.

To Users

Thank you for selecting LENNOX's product. Please read this instruction manual carefully before installing and using the product, so as to master and correctly use the product. In order to guide you to correctly install and use our product and achieve expected operating effect, we hereby instruct as below:

- (1) This appliance is not intended for use by persons (including children) with reduced physical, sensory or mental capabilities, or lack of experience and knowledge, unless they have been given supervision or instruction concerning use of the appliance by a person responsibility for their safety. Children should be supervised to ensure that they do not play with the appliance.
- (2) In order to ensure reliability of product, the product may consume some power under stand-by status for maintaining normal communication of system and preheating refrigerant and lubricant. If the product is not to be used for long, cut off the power supply; please energize and preheat the unit in advance before reusing it.
- (3) Please properly select the model according to actual using environment, otherwise it may impact the using convenience.
- (4) This product has gone through strict inspection and operational test before leaving the factory. In order to avoid damage due to improper disassembly and inspection, which may impact the normal operation of unit, please do not disassemble the unit by yourself. You can contact with the special maintenance center of our company if necessary.
- (5) When the product is faulted and cannot be operated, please contact with our maintenance center as soon as possible by providing the following information.
 - 1) Contents of nameplate of product (model, cooling/heating capacity, product No., ex-factory date).
 - 2) Malfunction status (specify the situations before and after the error occurs).
- (6) All the illustrations and information in the instruction manual are only for reference. In order to make the product better, we will continuously conduct improvement and innovation. We have the right to make necessary revision to the product from time to time due to the reason of sales or production, and reserve the right to revise the contents without further notice.
- (7) The final right to interpret for this instruction manual belongs to LENNOX.

Exception Clauses

Manufacturer will bear no responsibilities when personal injury or property loss is caused by the following reasons:

- (1) Damage the product due to improper use or misuse of the product.
- (2) Alter, change, maintain or use the product with other equipment without abiding by the instruction manual of manufacturer.
- (3) After verification, the defect of product is directly caused by corrosive gas.
- (4) After verification, defects are due to improper operation during transportation of product.
- (5) Operate, repair, maintain the unit without abiding by instruction manual or related regulations.
- (6) After verification, the problem or dispute is caused by the quality specification or performance of parts and components that produced by other manufacturers.
- (7) The damage is caused by natural calamities, bad using environment or force majeure.

Contents

1 Safety Notices (Please be sure to abide)	1
2 Product Introduction	3
2.1 Names of Main Parts	3
2.2 Combinations of Indoor and Outdoor Units	4
2.3 Operating Range	4
3 Preparation before Installation	4
3.1 Standard Parts	5
3.2 Installation Site	5
3.3 Piping Work Requirements	6
4 Installation Instruction	6
4.1 Dimension of Outdoor Unit and Mounting Hole	7
4.2 Connection Pipe	8
4.3 Installation of Connection Pipe.....	12
4.4 Disassembly of Compressor Feet.....	16
4.5 Vacuum Pumping, Refrigerant Adding	16
4.6 Electric Wiring.....	18
5 Check Items after Installation and Test Operation	21
5.1 Check Items after Installation.....	21
5.2 Test Operation and Debugging	21
6 Common Malfunctions and Troubleshooting	26
7 Error Indication	27
8 Maintenance and Care	29
8.1 Outdoor Heat Exchanger	29
8.2 Drain Pipe.....	30
8.3 Notice before Seasonal Use	30
8.4 Maintenance after Seasonal Use	30
8.5 Parts Replacement	30
9 After-sales Service	30

1 Safety Notices (Please be sure to abide)



WARNING: If not abide strictly, it may cause severe damage to the unit or the people.



NOTE! If not abide strictly, it may cause slight or medium damage to the unit or the people.



This sign indicates that the operation must be prohibited. Improper operation may cause severe damage or death to people.











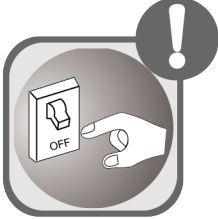

This sign indicates that the items must be observed. Improper operation may cause damage to people or property.



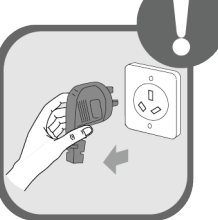

WARNING!

This product can't be installed at corrosive, inflammable or explosive environment or the place with special requirements, such as kitchen. Otherwise, it will affect the normal operation or shorten the service life of the unit, or even cause fire hazard or serious injury. As for above special places, please adopt special air conditioner with anti-corrosive or anti-explosion function.

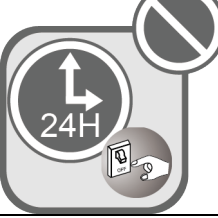
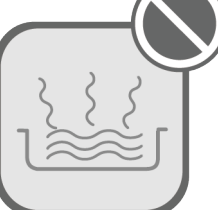
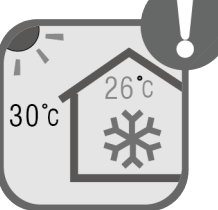
	<p>Please install the unit according to instructions in this manual. Read this manual carefully before starting up or checking the machine.</p>		<p>Installation should be performed by distributor or qualified technicians. Do not install the product by yourself. Improper installation may result in water leakage, electric shock or fire hazard.</p>
	<p>Before installation, please check the power cord if it complies with the power supply requirement on the nameplate. Make sure the power supply is safe.</p>		<p>This air conditioner must be properly grounded through the receptacle to avoid electric shock. The ground wire shouldn't be connected with gas pipe, water pipe, lightning arrester or telephone line.</p>
	<p>When installing, specialized parts and accessories must be used. Otherwise, it may result in water leakage, electric shock or fire hazard.</p>		<p>R410A refrigerant can produce poisonous gas once it meets fire, so please ventilate the room immediately if refrigerant leaks out during installation.</p>
	<p>Diameter of power cord must be large enough. Damaged power cord or connecting wire must be replaced by specialized electric cable.</p>		<p>After the power cord is connected, please install the cover of electric box to avoid danger.</p>
	<p>Nitrogen must be charged according to technical requirements.</p>		<p>Short circuit is forbidden. Do not cancel the pressure switch, otherwise unit may be damaged.</p>

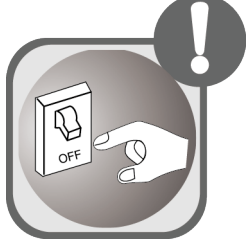
	<p>For units with wired controllers, do not connect power supply until the wired controller is well installed. Otherwise, the wired controller cannot be used.</p>		<p>When installation is finished, please check and make sure the drain pipe, pipeline and electric wire are all well connected so as to avoid water leakage, refrigerant leakage, electric shock and fire hazard.</p>
	<p>Do not extend fingers or objects into air outlet or return air grille.</p>		<p>If you use gas heater or petroleum heater in the same room, please open the door or window to maintain good air circulation, otherwise the room may be lack of oxygen.</p>
	<p>Never start or stop the air conditioner by inserting or removing the power cord.</p>		<p>Do not turn off the air conditioner until it runs for at least 5 minutes. Otherwise, oil return of the compressor will be affected.</p>
	<p>Children are not allowed to operate the air conditioner.</p>		<p>Do not operate the air conditioner with wet hands.</p>
	<p>Please turn off and unplug your air conditioner before cleaning. Otherwise, it may cause electric shock or personal injury.</p>		<p>Do not spray water on the air conditioner or it will cause malfunction or electric shock.</p>
	<p>Do not expose the air conditioner directly under damp or corrosive surroundings.</p>		<p>Connect power 8 hours before operation. Do not disconnect power when you want to stop the unit in a short period of time, e.g. in one night (This is for protecting the compressor).</p>
	<p>Volatile liquid like thinner or gasoline will damage the appearance of air conditioner (Please use soft dry cloth and wet cloth with mild detergent to clean unit's outer case).</p>		<p>Under cool mode, do not set the indoor temperature too low. Keep the difference between indoor temp and outdoor temp within 5°C.</p>

	<p>If abnormal condition occurs (e.g. unpleasant smell), please turn off the unit at once and disconnect power supply. Then contact LENNOX authorized service center. If the air conditioner continues to operate despite of abnormal condition, it may be damaged and cause electric shock or fire hazard.</p>		<p>Do not repair the air conditioner by yourself. Improper repair will cause electric shock or fire hazard. Please contact LENNOX authorized service center and ask professional technicians to repair it.</p>
<p>This appliance can be used by children aged from 8 years and above and persons with reduced physical, sensory or mental capabilities or lack of experience and knowledge if they have been given supervision or instruction concerning use of the appliance in a safe way and understand the hazards involved. Children shall not play with the appliance. Cleaning and user maintenance shall not be made by children without supervision. Install units according to national wiring codes. If the supply cord is damaged, it must be replaced by the manufacturer or its service agent or a similarly qualified person in order to avoid a hazard. An all-pole disconnection device which has at least 3mm clearances in all poles, and disconnection must be incorporated in the fixed wiring in accordance with the wiring rules.</p>			
<p>LENNOX will not assume responsibility for any personal injury or property loss caused by improper installation, improper debugging, unnecessary repair or not following the instructions of this manual.</p>			

2 Product Introduction

LENNO Multi VRF System adopts inverter compressor technology. By changing the displacement of compressor, stepless capacity regulation within range of 10%~100% can be realized. Various product lineups are provided with capacity range from 8kW to 18kW, which can be widely used in residential, commercial and working area and especially applicable to places with big load change. LENNOX residential air conditioner is absolutely your best choice.

2.1 Names of Main Parts

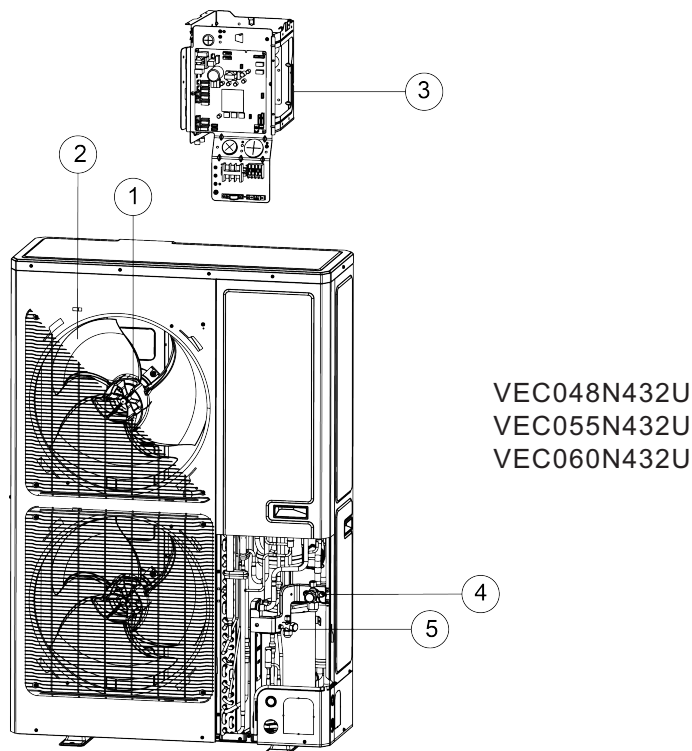

Fig 2.1.1

No.	①	②	③	④	⑤
Name	Motor	Fan blade	Electric box assembly	Gas pipe valve	Liquid pipe valve

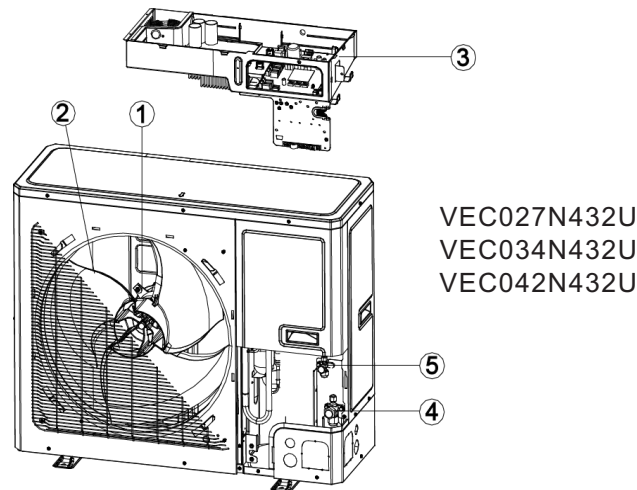

Fig 2.1.2

No.	①	②	③	④	⑤
Name	Motor	Fan blade	Electric box assembly	Gas pipe valve	Liquid pipe valve

2.2 Combinations of Indoor and Outdoor Units

- (1) See below the number of indoor units that can be connected to the outdoor unit.
- (2) The total capacity of indoor units should be within 50%~135% of that of the outdoor unit.

Model	Min sets of connectable IDUs	Max sets of connectable IDUs
VEC027N432U	2	4
VEC034N432U	2	5
VEC042N432U	2	6
VEC048N432U	2	8
VEC055N432U	2	9
VEC060N432U	2	10

- (3) Can be connected to various indoor units. When any one of the indoor units receives operating command, outdoor unit will start operation as per required capacity. When all indoor units stop, outdoor unit will be shut off.

2.3 Operating Range



Cooling	Outdoor temperature: -5°C~48°C
---------	--------------------------------

3 Preparation before Installation





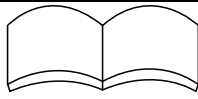
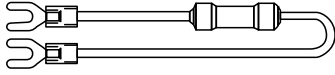

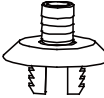
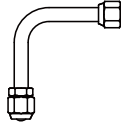
! **NOTE!** Graphics here are only for reference. Please refer to actual products. Unspecified dimensions are all in mm.

3.1 Standard Parts

Please use the supplied standard parts as required.

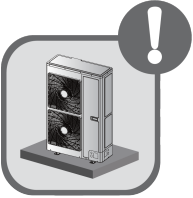
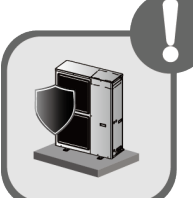
Parts for Outdoor Unit				
No.	Name	Appearance	Qty	Remark
1	User Manual		1	
2	Wiring (match with resistance)		1	Must be connected to the last IDU of communication connection
3	Corrugated pipe		1	
4	Chassis gluey plug		3	
5	Drainage joint		1	
6	Tube Connector Sub-assy		1	VEC027N432U VEC034N432U VEC042N432U

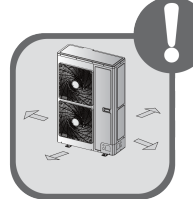
3.2 Installation Site

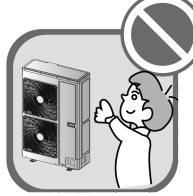
 Forbidden item! Improper operation might lead to personal injury or even death.			
 Item needs to be followed. Improper operation might lead to personal injury or property damage.			
	Select a location which is strong enough to hold unit's weight so that unit can stand still and erect.		The installation position should withstand strong wind, typhoon and earthquake. The unit must be installed stably.
	Please keep the unit away from inflammable, explosive and corrosive gas or waste gas.		Make sure the location has space for heat exchange and maintenance so that unit can operate reliably with good ventilation.
	ODU and IDU should stay as close as possible to shorten the length of refrigerant pipe and reduce bend angles.		Select a location which is out of children's reach. Keep the unit away from children.

If the ODU is totally surrounded by walls, please refer to the following figures for space dimension:

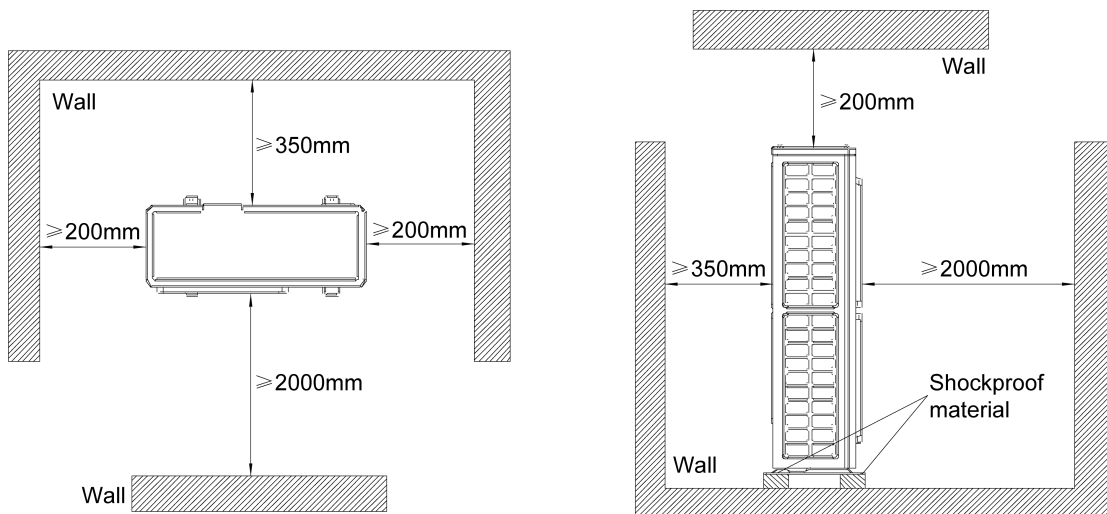

Fig 3.2.1

3.3 Piping Work Requirements

Refer to the table below for piping work requirements:

R410A Refrigerant System	
Outer diameter (mm/inch)	Wall thickness (mm)
Φ6.35(1/4)	≥0.8
Φ9.52(3/8)	≥0.8
Φ12.70(1/2)	≥0.8
Φ15.9(5/8)	≥1.0
Φ19.05(3/4)	≥1.0

4 Installation Instruction

NOTE! Graphics here are only for reference. Please refer to actual products. Unspecified dimensions are all in mm.

4.1 Dimension of Outdoor Unit and Mounting Hole

Unit Outline and Installation Dimension(mm).

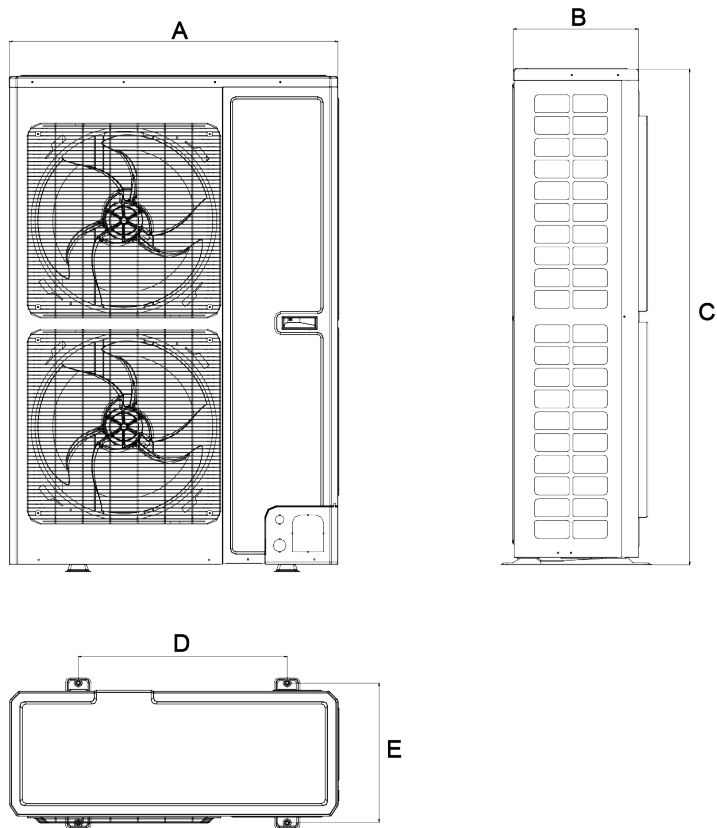

Fig 4.1.1

Unit:mm

Model	A	B	C	D	E
VEC048N432U	900	340	1345	572	378
VEC055N432U					
VEC060N432U					

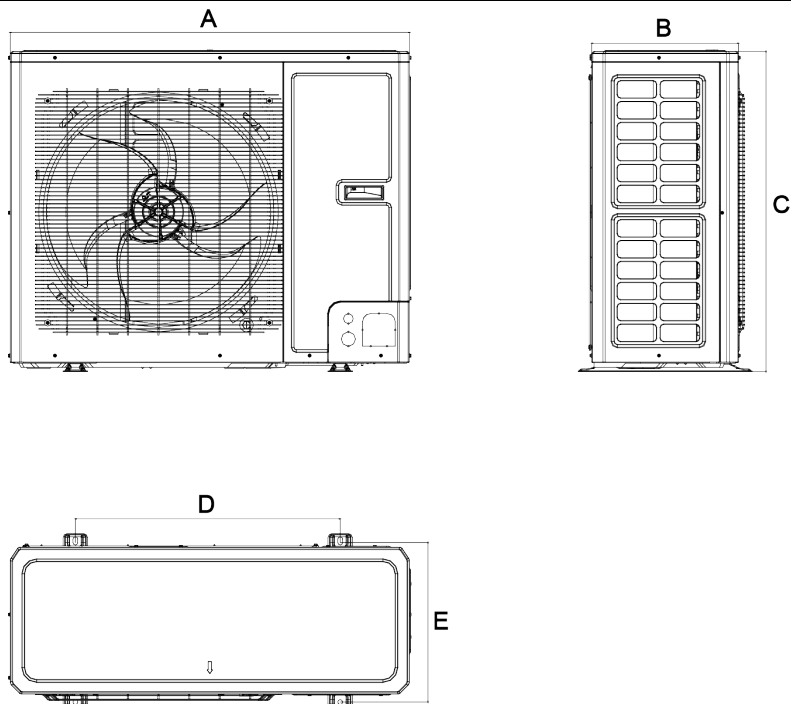

Fig 4.1.2

Unit:mm

Model	A	B	C	D	E
VEC027N432U	980	360	790	650	395
VEC034N432U					
VEC042N432U					

4.2 Connection Pipe

4.2.1 Schematic Diagram of Piping Connection

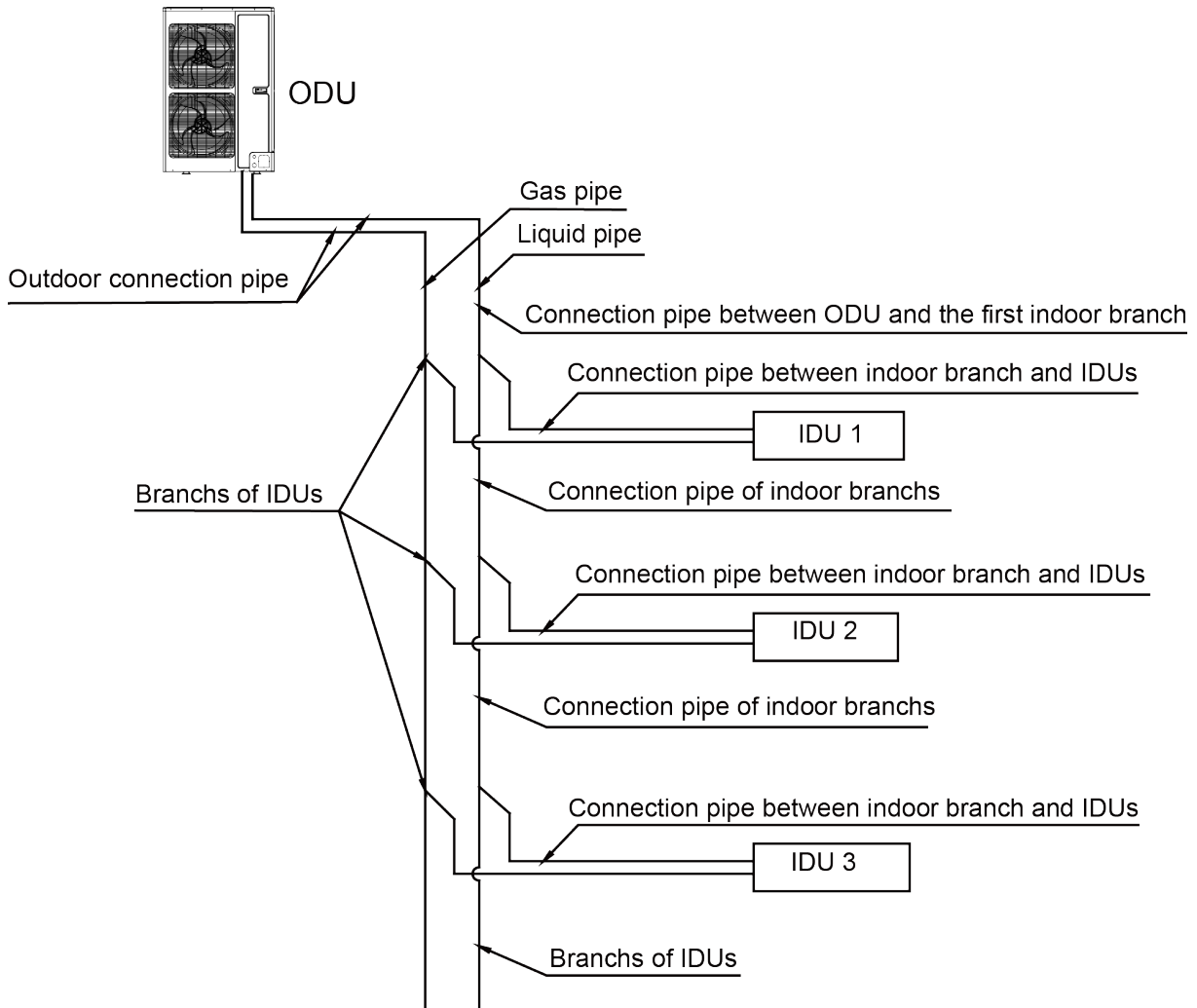

Fig.4.2.1.1

4.2.2 Allowable Length and Height Difference of Connection Pipe

Y type branch joint is adopted to connect indoor and outdoor units. Connecting method is shown in the figure below:

NOTE! Equivalent length of one Y-type branch is 0.5m.

Piping parameters of VEC027N432U, VEC034N432U, VEC042N432U.

		Allowable value	Fitting pipe
Total length (actual length) of fitting pipe		250m	$L1+L2+L3+a+b+c+d$
Length of farthest fitting pipe (m)	Actual length	100m	$L1+L2+L3+d$
	Equivalent length	120m	
From the 1 st branch to the farthest indoor pipe		40m	$L2+L3+d$

		Allowable value	Fitting pipe
Height difference between ODU and IDU	ODU at upper side	30m	—
	ODU at lower side	30m	—
Height difference between IDUs		10m	—

Piping parameters of VEC048N432U, VEC055N432U, VEC060N432U.

		Allowable value	Fitting pipe
Total length (actual length) of fitting pipe		300m	$L1+L2+L3+a+b+c+d$
Length of farthest fitting pipe (m)	Actual length	120m	$L1+L2+L3+d$
	Equivalent length	150m	
From the 1 st branch to the farthest indoor pipe		40m	$L2+L3+d$
Height difference between ODU and IDU	ODU at upper side	50m	—
	ODU at lower side	40m	—
Height difference between IDUs		15m	—

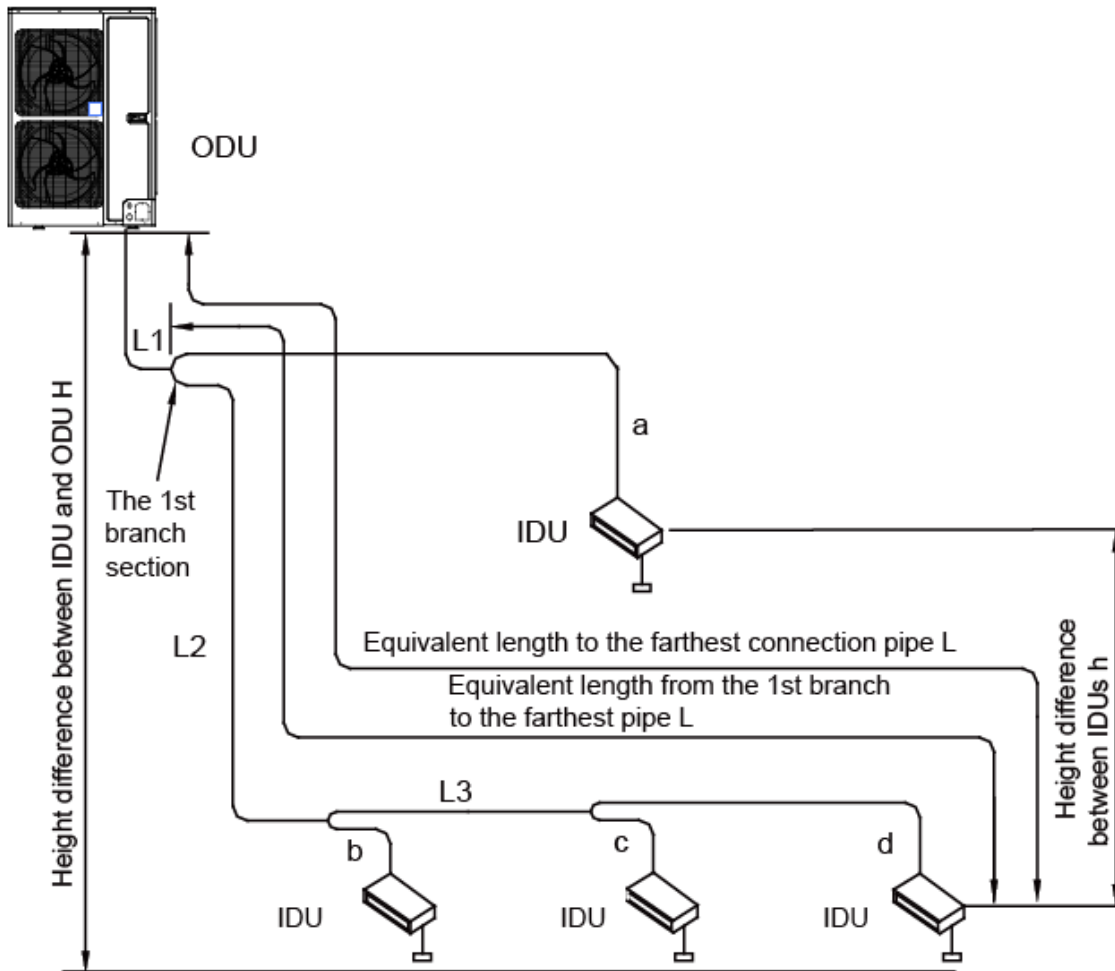

Each Y-type branch equals to 0.5m and each branch header equals to 1.0m.

Fig 4.2.2.1 Allowable Length and Height Difference of Connection Pipe

4.2.3 Dimension of Pipe (Main Pipe) from ODU to the 1st Indoor Branch

Dimension of pipe from ODU to the 1st indoor branch will be determined by the dimension of outdoor connection pipe.

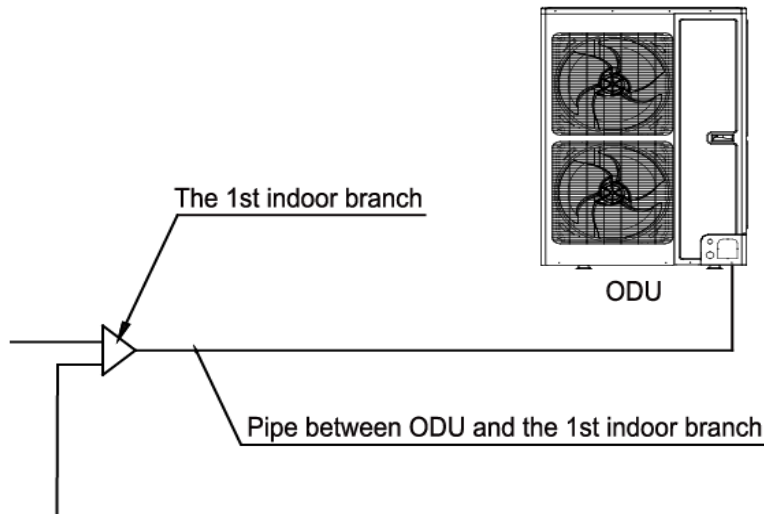

Fig 4.2.3.1

Dimension of outdoor connection pipe.

Basic module	Pipe dimension	
	Gas pipe (mm)	Liquid pipe (mm)
VEC027N432U	Φ15.9	Φ9.52
VEC034N432U	Φ15.9	Φ9.52
VEC042N432U	Φ15.9	Φ9.52
VEC048N432U	Φ15.9	Φ9.52
VEC055N432U	Φ19.05	Φ9.52
VEC060N432U	Φ19.05	Φ9.52

4.2.4 Selection of Indoor Branches

Select indoor branches according to the total capacity of downstream indoor units. If the capacity exceeds that of the outdoor unit, capacity of outdoor unit prevails.

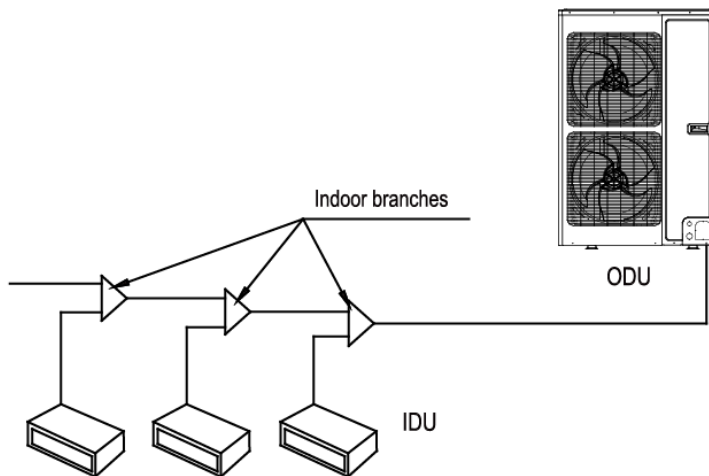

Fig 4.2.4.1

R410A Refrigerant system	Total capacity of downstream indoor units X (kW)	Model
Y type branch	$X < 20$	VEBC01A
	$20 \leq X \leq 30$	VEBC01B
	$30 < X \leq 70$	VEBC02A
	$70 < X \leq 135$	VEBC03A
	$135 < X$	VEBC04A

4.2.5 Dimension of Pipe between Indoor Branches

Select pipe between indoor branches according to the capacity of downstream indoor units; if the capacity exceeds that of the outdoor unit, capacity of outdoor unit prevails.

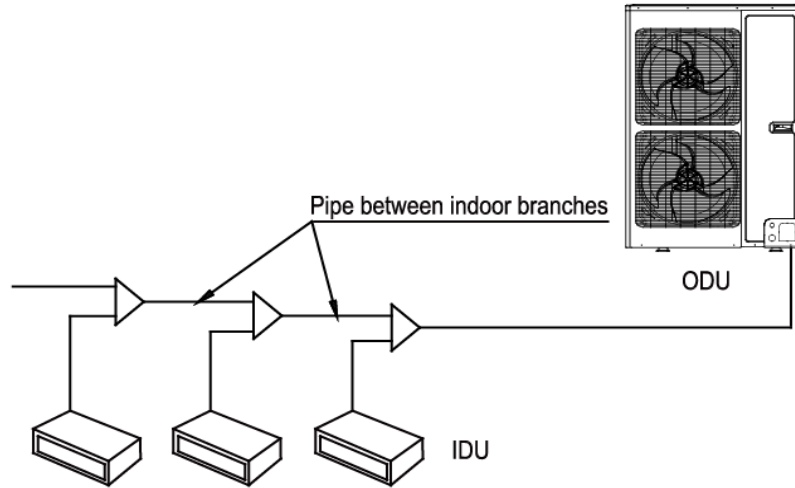

Fig 4.2.5.1

Total capacity of downstream indoor units C (kW)	Gas pipe (mm)	Liquid pipe (mm)
$C \leq 5.6$	$\Phi 12.7$	$\Phi 6.35$
$5.6 < C \leq 14.2$	$\Phi 15.9$	$\Phi 9.52$
$14.2 < C \leq 22.4$	$\Phi 19.05$	$\Phi 9.52$

4.2.6 Dimension of Pipe between Indoor Branch and IDU

Dimension of pipe between indoor branch and IDU should be consistent with the dimension of indoor pipe.

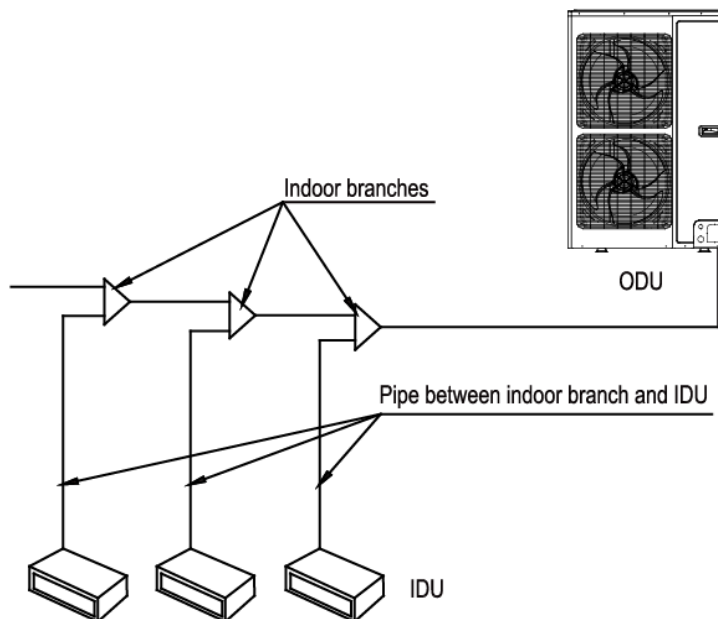

Fig 4.2.6.1

Rated capacity of IDU C(kW)	Gas pipe (mm)	Liquid pipe (mm)
$C \leq 2.8$	$\Phi 9.52$	$\Phi 6.35$
$2.8 < C \leq 5.0$	$\Phi 12.7$	$\Phi 6.35$
$5.0 < C \leq 14.0$	$\Phi 15.9$	$\Phi 9.52$
$14.0 < C \leq 16.0$	$\Phi 19.05$	$\Phi 9.52$
$16.0 < C \leq 28.0$	$\Phi 22.2$	$\Phi 9.52$

NOTE! If the distance between IDU and its nearest branch is over 10m, then the liquid pipe of IDU (rated capacity ≤ 5.0 kW) shall be enlarged.

4.3 Installation of Connection Pipe

4.3.1 Precautions for the Installation of Connection Pipe

- (1) Conform to the following principles during pipe connection: Connection pipe should be as short as possible, so is the height difference between indoor and outdoor units. Keep the number of bends as little as possible. Radius of curvature should be as large as possible.
- (2) Weld the connection pipe between indoor and outdoor units. Please strictly follow the requirements for welding process. Rosin joint or pin hole is not allowed.
- (3) Radius of bending parts should be over 200mm. Note that pipes cannot be repeatedly bent or stretched; otherwise the material will get harder. Do not bend or stretch the pipe for more than 3 times at the same position.

4.3.2 Flaring Process

- (1) Use pipe cutter to cut the connection pipe in case it is unshaped.
- (2) Keep the pipe downward in case cutting scraps get into the pipe. Clear away the burrs after cutting.
- (3) Remove the flared nut connecting indoor connection pipe and outdoor unit. Then use flaring tool to fix the flared nut into the pipe (as shown in Fig.4.3.2.1).
- (4) Check if the flared part is flaring evenly and if there is any crack.

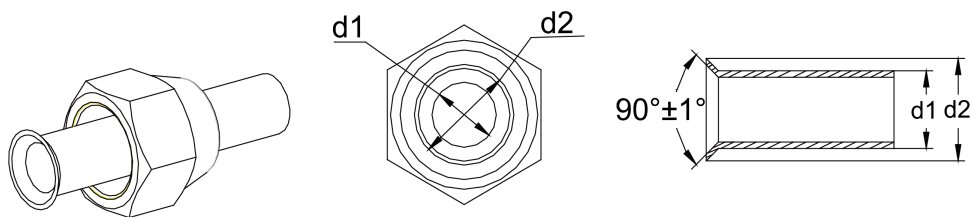

Fig 4.3.2.1

4.3.3 Pipe Bending

- (1) Reshape the pipe by hand. Be careful not to damage the pipe.

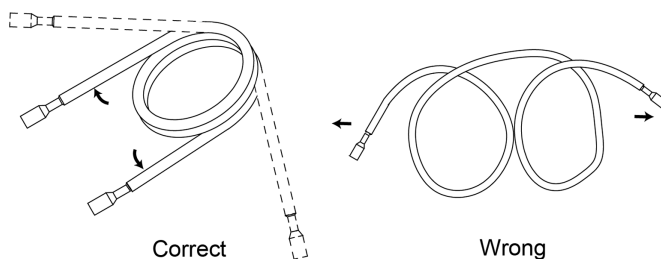

Fig 4.3.3.1

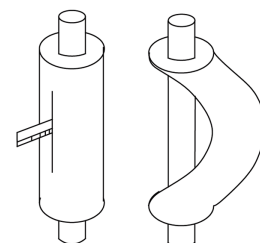

Fig 4.3.3.2

- (2) Do not bend the pipe over 90°.
- (3) If pipe is repeatedly bent or stretched, it will get hard and difficult to bend and stretch again. Therefore, do not bend or stretch the bend for over 3 times.
- (4) In case that direct bending will open cracks to the pipe, first use sharp cutter to cut the insulating layer, as shown in Fig.4.3.3.2. Do not bend the pipe until it is exposed. When bending is done, wrap the pipe with insulating layer and then secure it with adhesive tape.

4.3.4 Indoor Pipe Connection

- (1) Remove pipe cover and pipe plug.
- (2) Direct the flared part of copper pipe to the center of screwed joint. Twist on the flared nut tightly by hand, as in Fig 4.3.4.1 (Make sure indoor pipe is correctly connected. Improper location of the center will prevent flared nut from being securely twisted. Thread of nut will get damaged if the flared nut is twisted forcibly).
- (3) Use torque wrench to twist on the flared nut tightly until the wrench gives out a click sound (Hold the wrench and make it at right angle to the pipe as in Fig 4.3.4.2).
- (4) Use sponge to wrap the un-insulated connection pipe and joint. Then tie the sponge tightly with plastic tape.
- (5) Connection pipe should be supported by a bearer rather than the unit.
- (6) The bending angle of piping should not be too small; otherwise the piping might have cracks. Please use a pipe bender to bend the pipe.
- (7) When connecting IDU with connection pipe, do not pull the big and small joints of IDU with force in case the capillary tube or other tubes have cracks and cause leakage.

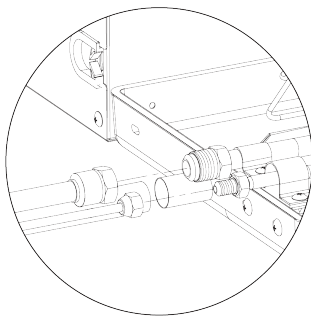

Fig 4.3.4.1

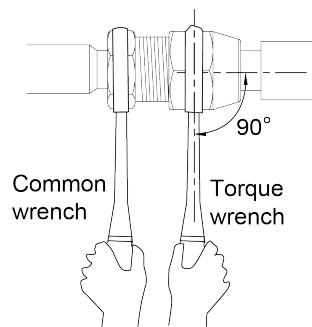

Fig 4.3.4.2

Pipe diameter	Tightening torque
Φ6.35mm	15~30(N·m)
Φ9.52mm	35~40(N·m)
Φ12.7mm	45~50(N·m)
Φ15.9mm	60~65(N·m)

4.3.5 Outdoor Pipe Connection

Twist the flared nut on the connection pipe of outdoor valves. Twisting method is the same as for indoor pipe connection.

During engineering installation, the connection pipe inside the unit must be wrapped by insulation sleeve.

Below is the piping diagram of VEC027N432U, VEC034N432U, VEC042N432U, VEC048N432U, VEC055N432U, VEC060N432U.

According to customer requirement or space limit, outlet pipe can be installed from the front, right or rear side.

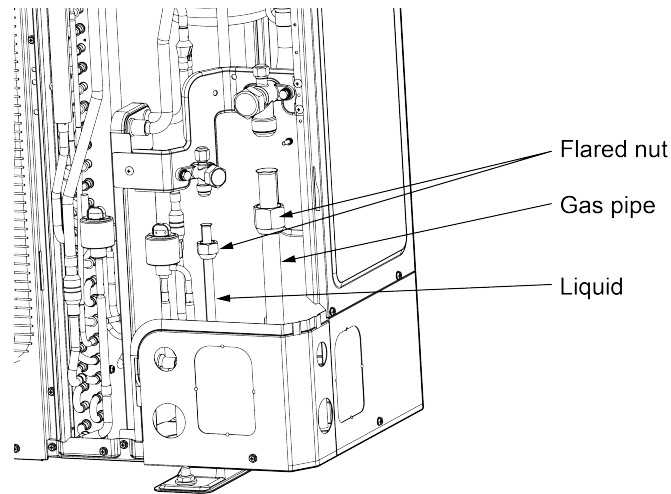

Fig 4.3.5.1

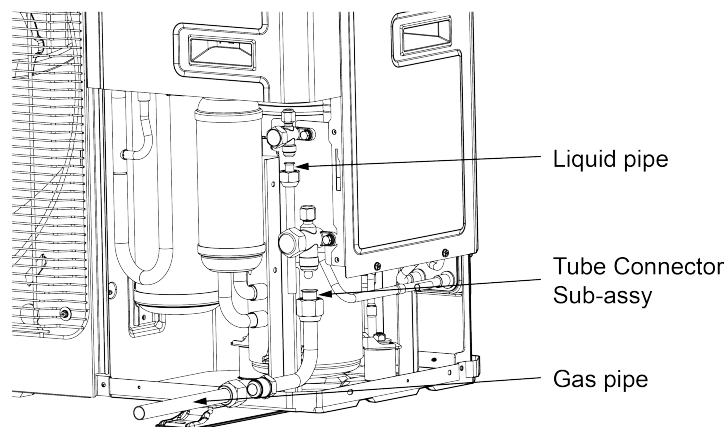

Fig 4.3.5.2

4.3.6 Installation of Y-type Branch

(1) Y-type Branch.

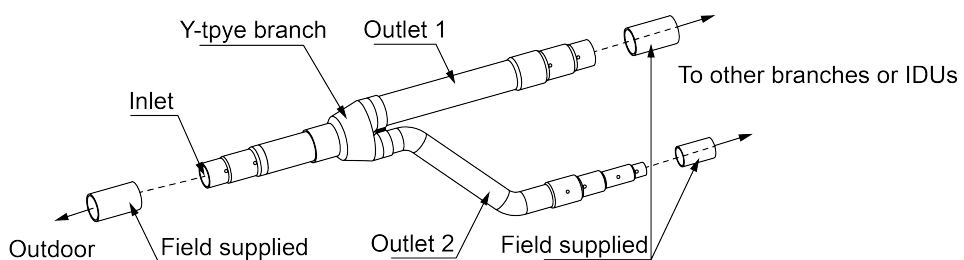

Fig 4.3.6.1

- (2) Y-type branch has several pipe sections with different dimension, which facilitates to match with various copper pipes. Use pipe cutter to cut in the middle of the pipe section that is of proper dimension and remove burrs as well. See Fig. 4.3.6.2.
- (3) Y-type branch must be installed vertically or horizontally.

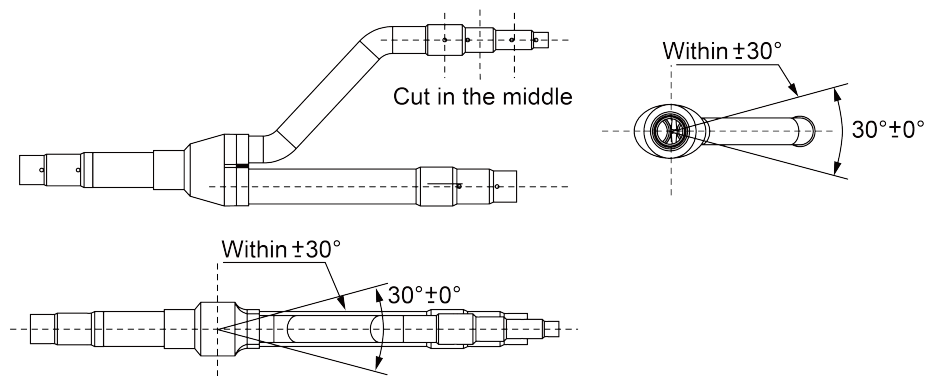

Fig 4.3.6.2

- (4) Branch shall be isolated by insulating material that can bear 120°C or even higher temperature. The attached foam of branch cannot be taken as insulating material.

4.3.7 Thermal Insulation for Pipeline

- (1) For multi VRF system, every copper pipe should be labeled so as to avoid misconnection.
- (2) At the branch inlet, leave at least 500mm straight pipe section.
- (3) Thermal insulation for pipeline.
 - 1) To avoid condensate or water leakage on the connection pipe, the gas pipe and liquid pipe must be wrapped with thermal insulating material and adhesive tape for insulation from the air.
 - 2) Thermal insulating material shall be able bear the pipe temperature. For heat pump unit, liquid pipe should bear 70°C or above and gas pipe should bear 120°C or above. For cooling only unit, both liquid pipe and gas pipe should bear 70°C or above.
 - 3) Example: Polyethylene foam (bear 120°C or above); foaming polyethylene (bear 100°C or above).
 - 4) Joints of indoor and outdoor unit should be wrapped with insulating material and leave no gap between pipe and wall. See Fig.4.3.7.1.

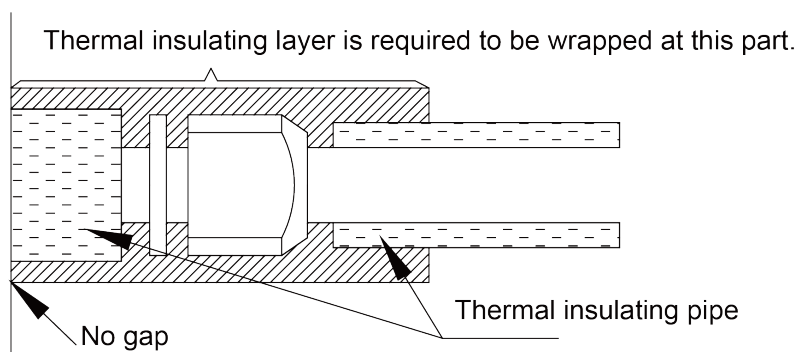

Fig 4.3.7.1

- 5) Thermal insulating material of branches should be the same as that of the pipeline. The attached foam of branches cannot be taken as insulating material.
- 6) When wrapping the tape, the later circle should cover half of the former one. Don't wrap the tape too tight, otherwise the insulation effect will be weakened.
- 7) After wrapping the pipe, apply sealing material to completely seal the hole on the wall.

4.3.8 Support and Protection of Pipeline

- (1) Support should be made for hanging connection pipe. Distance between each support cannot be over 1m.
- (2) Protection against accidental damage should be made for outdoor pipeline. When pipeline exceeds 1m, a pinch board should be added for protection.

4.4 Disassembly of Compressor Feet

In order to prevent unit from damage during transportation, 2 metal pieces are fitted to outdoor unit's compressor feet before unit leaves factory. See Fig.4.4.1.

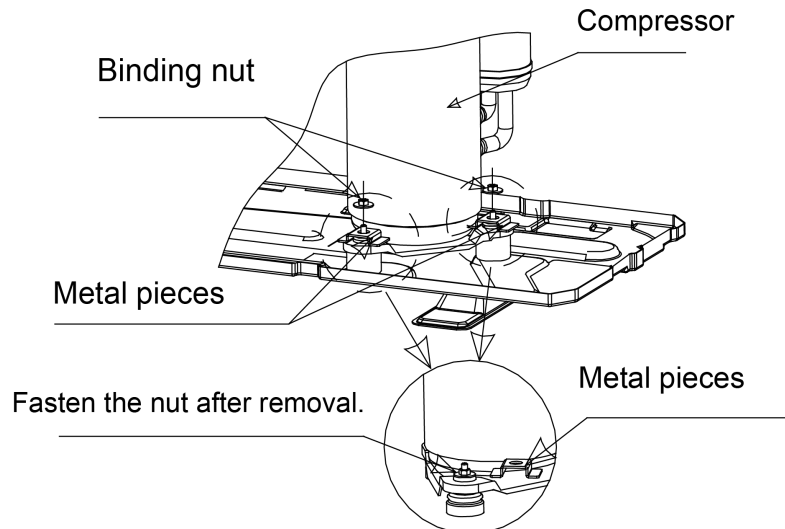

Fig 4.4.1

When installing the unit, metal pieces for transportation must be removed. Then fasten the binding nuts again and wrap back soundproofing cotton.



NOTE! If unit runs with metal pieces fitting on, compressor will shake abnormally and unit's operating life will be shortened.

4.5 Vacuum Pumping, Refrigerant Adding

4.5.1 Vacuum Pumping

- (1) Outdoor unit has been charged with refrigerant before delivery. Field-installed connection pipe needs to be charged with additional refrigerant.
- (2) Confirm whether outdoor liquid and gas valves are closed.

- (3) Use vacuum pump to withdraw the air inside indoor unit and connection pipe from the outdoor valve, as shown below.

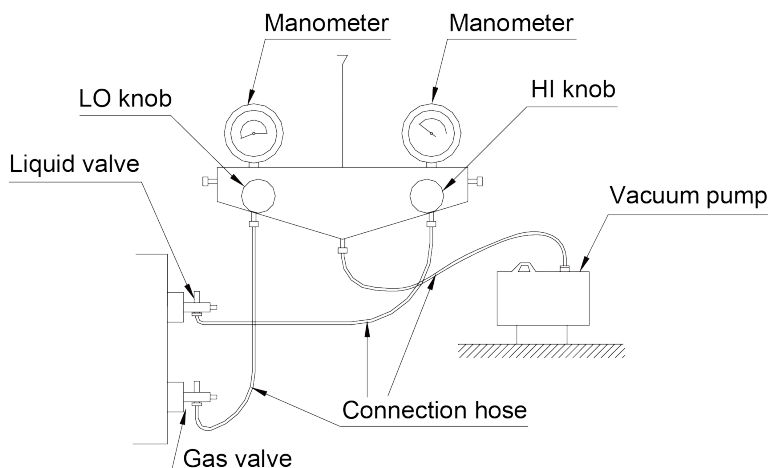

Fig 4.5.1.1

4.5.2 Refrigerant Adding

- (1) Refrigerant quantity of outdoor unit before delivery:

Model	VEC027N432U	VEC034N432U	VEC042N432U
Refrigerant Qty (kg)	2.09	2.09	2.29
Model	VEC048N432U	VEC055N432U	VEC060N432U
Refrigerant Qty (kg)	3.3	3.3	3.3



NOTES!

- ① The refrigerant amount charged before delivery doesn't include the amount that needs to be added to indoor units and the connection pipeline.
- ② Length of connection pipe is decided on site. Therefore the amount of additional refrigerant shall be decided on site according to the dimension and length of field-installed liquid pipe.
- ③ Record the amount of additional refrigerant for convenience of after-sales service.

- (2) Calculation of the amount of additional refrigerant.

Calculation method of the quantity of additional refrigerant (based on liquid pipe)

Quantity of additional refrigerant = \sum length of liquid pipe \times quantity of additional refrigerant per meter + (quantity of indoor unit - 2) \times 0.3

Quantity of additional refrigerant per meter for liquid pipe(kg/m)					
Φ22.2	Φ19.05	Φ15.9	Φ12.7	Φ9.52	Φ6.35
0.35	0.25	0.17	0.11	0.054	0.022

First confirm that there is no leakage from the system. When compressor is not working, charge additional R410A with specific amount to the unit through the filling opening of the liquid pipe valve of the outdoor unit. If required amount cannot be quickly filled due to pressure increase of the pipe, then set the unit in cooling startup and fill refrigerant from the low pressure check valve of the outdoor unit.

(3) Calculation example.

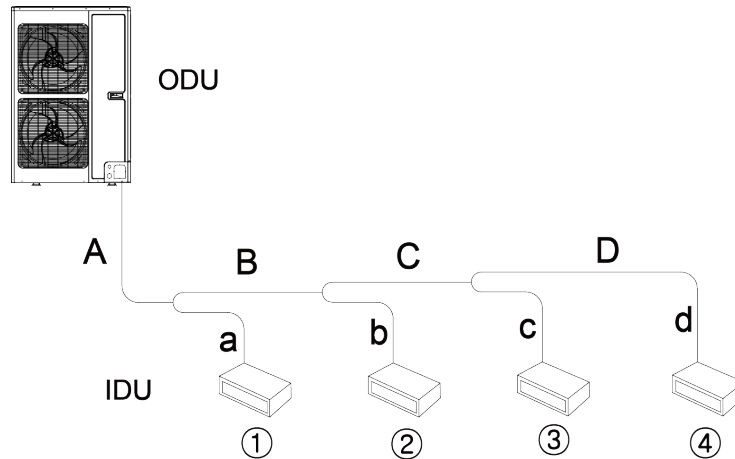

Fig 4.5.2.1

IDU:

No.	IDU ①	IDU ②	IDU ③	IDU ④
Model	Duct type VESD024N432U	Duct type VESD017N432U	Duct type VESD012N432U	Duct type VESD008N432U

Liquid pipe:

No.	A	B	C	D
Pipe size	Φ9.52	Φ9.52	Φ9.52	Φ6.35
Length	10m	5m	5m	5m
No.	a	b	c	d
Pipe size	Φ9.52	Φ6.35	Φ6.35	Φ6.35
Length	3m	3m	2m	1m

Total length of each liquid pipe

Φ9.52: $A+B+C+a=10+5+5+3=23\text{m}$ Φ6.35: $D+b+c+d=5+3+2+1=11\text{m}$

Quantity of indoor unit: 4 sets

Therefore, the minimum quantity of additional refrigerant = $(23 \times 0.054 + 11 \times 0.022) + (4 - 2) \times 0.3 = 2.084\text{kg}$

4.6 Electric Wiring

4.6.1 Notices for Wiring

- (1) Install units according to national wiring codes.
- (2) Use air conditioner specialized power supply and make sure that it is consistent with system's rated voltage.
- (3) Do not pull the power cord with force.
- (4) All electrical installation must be performed by qualified technicians in accordance with local laws, regulations and this user manual.
- (5) Caliber of the power cord must be large enough. A damaged power cord or connection wire must be replaced by specialized electrical cords.
- (6) If the supply cord is damaged, it must be replaced by the manufacturer or its service agent or a similarly qualified person in order to avoid a hazard.

- (7) An all-pole disconnection device which has at least 3mm clearances in all poles, and disconnection must be incorporated in the fixed wiring in accordance with the wiring rules.
- (8) Details of type and rating for fuse:
 Model: VEC048N432U, VEC055N432U, VEC060N432U.
 Ceramic 250V5A (front main board), ceramic 250V3.15A (back main board).
 Model: VEC027N432U, VEC034N432U, VEC042N432U.
 Ceramic 250V5A (front main board), ceramic 250V30A (front main board).
- (9) Connect the unit to specialized grounding device and make sure it is securely grounded. It's a must to install air switch and current circuit breaker that can cut off the power of the entire system. The circuit breaker should include magnetic trip function and thermal trip function so that system can be protected from short circuit and overload.
- (10) Grounding Requirements.
 - 1) Air conditioner belongs to class I electrical appliance, so it must be securely grounded.
 - 2) The yellow-green wire inside the unit is a ground wire. Do not cut it off or secure it with tapping screws, otherwise it will lead to electric shock.
 - 3) Power supply must include secure grounding terminal. Do not connect the ground wire to the following:
 - ① Water pipe; ② Gas pipe; ③ Drain pipe;
 - ④ Other places that are deemed as not secure by professional technicians.

4.6.2 Wiring Diagram

- (1) Connection of power cord and communication wire Separate power supply for IDU and ODU.

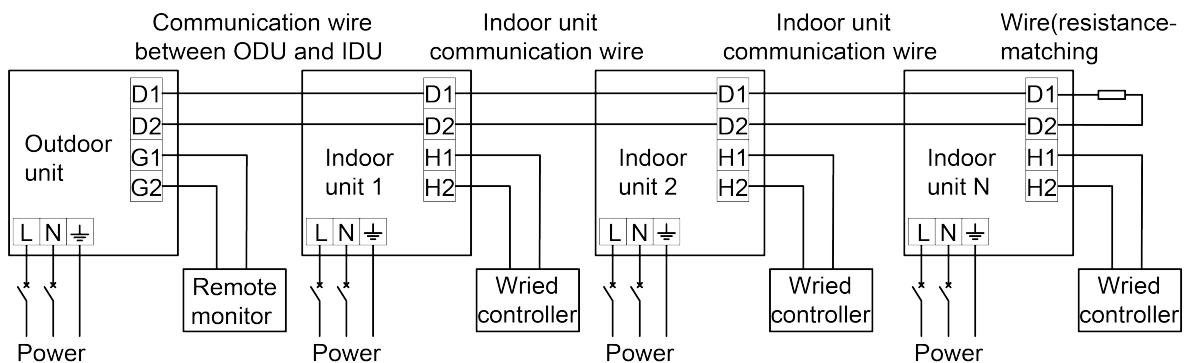

Fig 4.6.2.1 Connection of power cord and communication wire for IDU and ODU

- (2) Selection of circuit breaker and power cord.

Model	Power supply	Circuit breaker capacity (A)	Number of ground wire × Min sectional area (mm ²)	Number of power cord × Min sectional area (mm ²)
VEC027N432U	220~240V 50Hz 208~230V 60Hz	25	1×2.5	2×2.5
VEC034N432U	220~240V 50Hz 208~230V 60Hz	25	1×2.5	2×2.5
VEC042N432U	220~240V 50Hz 208~230V 60Hz	32	1×2.5	2×2.5
VEC048N432U	220~240V 50Hz 208~230V 60Hz	40	1×6.0	2×6.0

Model	Power supply	Circuit breaker capacity (A)	Number of ground wire × Min sectional area (mm ²)	Number of power cord × Min sectional area (mm ²)
VEC055N432U	220~240V 50Hz 208~230V 60Hz	40	1×6.0	2×6.0
VEC060N432U	220~240V 50Hz 208~230V 60Hz	40	1×6.0	2×6.0

! NOTES!

- ① Selection of circuit breaker and power cord in the above table is based upon unit's maximum power (maximum current).
- ② Specification of power cord is based on the working condition where ambient temperature is 40°C and multi-core copper cable (working temperature is 90°C, e.g. power cable with YJV cross-linked copper, insulated PE and PVC sheath) is lying on the surface of slot. If working condition changes, please adjust the specification according to national standard.
- ③ Specification of circuit breaker is based on the working condition where ambient temperature of circuit breaker is 40°C. If working condition changes, please adjust the specification according to national standard.

4.6.3 Engineering Wiring of Power Supply and Communication Cable

- (1) Please refer Fig 4.6.3.1 and 4.6.3.2 for engineering wiring. If there is the hole for cable tie in wiring route, please fix the wire with cable tie. Connect the power cord and communication cable to the corresponding terminal board and grounding screw according to the wiring diagram.
- (2) Please be noted that engineering wiring cannot touch the pipe and appliance.
- (3) This figure is only applicable for engineering wiring reference of power supply and communication cable. If there are differences between the figure structure and actual unit, please refer to the actual unit.
- (4) For engineering wiring, please refer to the wiring diagram provided with the unit.

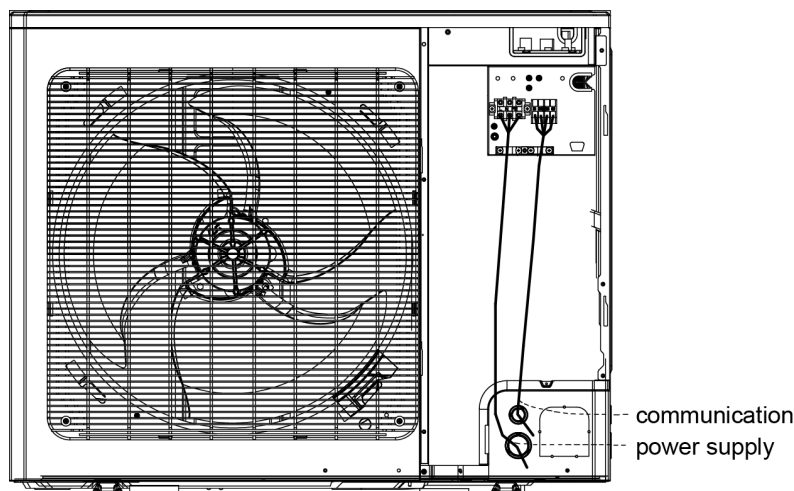

Fig 4.6.3.1 Engineering Wiring View of VEC027N432U, VEC034N432U, VEC042N432U

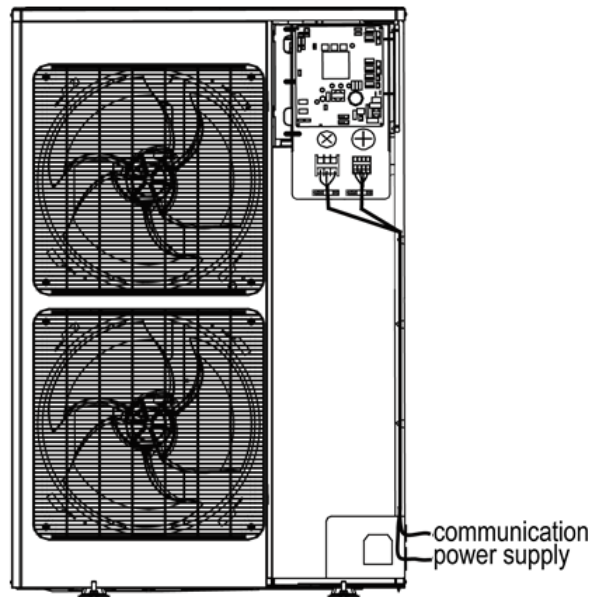

Fig 4.6.3.2 Engineering Wiring View of VEC048N432U, VEC055N432U, VEC060N432U

5 Check Items after Installation and Test Operation

5.1 Check Items after Installation

Check items	Possible conditions due to improper installation	Check
Each part of the unit is installed securely?	Unit may drop, shake or emit noise.	
Gas leakage test is taken or not?	Insufficient cooling (heating) capacity.	
Unit gets proper thermal insulation or not?	There may be condensation and dripping.	
Drainage is smooth or not?	There may be condensation and dripping.	
Is the voltage in accordance with the rated voltage specified on the nameplate?	Unit may have malfunction or components may get damaged.	
is the electric wiring and pipe connection installed correctly?	Unit may have malfunction or components may get damaged.	
Unit is securely grounded or not?	Electrical leakage.	
Power cord meets the required specification?	Unit may have malfunction or components may get damaged.	
Is the air inlet/outlet blocked?	Insufficient cooling (heating) capacity.	
Length of refrigerant pipe and the charging amount of refrigerant are recorded or not?	The refrigerant charging amount is not accurate.	
Binding pieces on compressor feet are removed or not?	Compressor may get damaged.	

5.2 Test Operation and Debugging

!NOTES!

- ① After finishing the first installation or replacing the main board of outdoor unit, it is necessary to perform test operation and debugging. Otherwise, unit won't be able to work.
- ② Test operation and debugging must be performed by professional technicians or under the guidance of professional technicians.

5.2.1 Prepare the Test Operation and Debugging

- (1) Do not connect power until all installation work is finished.

- (2) All control circuits and wires are correctly and securely connected.
- (3) Check whether the fixing loops for compressor foots are removed.
- (4) All small pieces, especially metal chips, thread ends and forceps holder, must be removed from the unit.
- (5) Check whether unit's appearance and pipeline system has been damaged during transportation.
- (6) Calculate the quantity of refrigerant that needs to be added according to the pipe length. Pre-charge the refrigerant. In case that the required charging quantity is not reached while refrigerant can't be added, record the quantity of refrigerant that still needs to add and complement the quantity during test operation. For details of adding refrigerant during test operation, see below.
- (7) After refrigerant is added, make sure valves of outdoor unit are completely open.
- (8) For the convenience of troubleshooting during debugging, unit shall be connected to a PC with applicable debugging software. Make sure unit's real-time data can be checked through this computer. The installation and connection of debugging software can be found in the Service Manual.
- (9) Before test operation, make sure unit is power on and compressor has been preheated for more than 8 hours. Touch the unit to check whether it's normally preheated. If yes, start test operation. Otherwise, compressor might be damaged.

5.2.2 Test Operation and Debugging

Description of test operation procedures and main board display of ODU

Description of each stage of debugging progress			
Progress	Debugging code		Code meaning and operation method
	LED		
	Code	Display status	
01_Set master unit	A0	ON	System is not debugged, hold main board's SW3 button for 5s to start debugging.
	01	ON	2s later, next step starts.
02_Allocate addresses	02/Ad	Display circularly	System is allocating addresses. 10s later, display as below:
	02/L7	Display circularly	No master indoor unit. Display will be on for 1min, during which master IDU can be set manually. If not, system will set the unit with minimum IP address as the master IDU.
	02/oC	Display circularly	Allocation is finished. 2s later, next step starts.
03_Confirm the quantity of ODU	03/01	Display circularly	System is confirming. 1s later, next step starts.
04_Confirm the quantity of IDU	04/00~16	Display circularly	"00~16" displays the quantity of indoor unit. Confirm the number manually. If the number is not consistent the display one, cut off power of IDU and ODU and check whether communication wire of IDU is correctly connected. After the check, connect power and start debugging from progress 01. If the number is then correct, press main board's SW3 button to confirm. Then the display is as below:
	04/oC	Display circularly	System has confirmed the quantity. 2s later, next step starts.

Description of each stage of debugging progress			
Progress	Debugging code		Code meaning and operation method
	LED		
	Code	Display status	
	00~16/CL	Display circularly	"00~16" displays the quantity of indoor unit identified by the system. "CL" means the amount of indoor unit is very little (amount of indoor unit<2), at this moment, all buttons are invalid, the system cannot enter into the next judgment.
05_ Detect ODU's internal communication and capacity ratio	05/C2	Display circularly	Communication between master ODU and driver has error. Check the communication connection of ODU's main board and drive board. When the error is eliminated, start next step. If power is off during troubleshooting, then restart debugging from progress 01 after power is on.
	05/oC	Display circularly	Communication of master ODU and driver is normal. Unit will display as in the left for 2s and detect the capacity ratio of IDU and ODU. If the ratio is within range, then next step will start 2s later. If the ratio is out of range, unit will display as below:
	05/CH	Display circularly	Rated capacity ratio of IDU is too high. Change the combination way of IDU and ODU to make the ratio within range. And restart debugging from progress 01.
	05/CL	Display circularly	Rated capacity ratio of IDU is too low. Change the combination way of IDU and ODU to make the ratio within range. And restart debugging from progress 01.
06_ Detect outdoor components	06/error code	Display circularly	Outdoor component's error. Besides "06", the other blinking will display the related error code. After errors are eliminated, system will start next step automatically. If power is off during troubleshooting, then restart debugging from progress 01 after power is on.
	06/oC	Display circularly	System detects no error on outdoor component. 10s later, next step starts.
07_ Detect indoor components	07/XX/error code	Display circularly	System detects error on indoor components. XX means the project code of IDU with error, e.g. no.1 IDU has d5 and d6 errors, meanwhile no.3 IDU displays error d6 and d7, then the nixie tube will display "07", "01", "d5", "d6"and "03" circularly. After errors are eliminated, system will start next step automatically. If power is off during troubleshooting, then restart debugging from progress 01 after power is on.
	07/XXXX/error code	Display circularly	If errors occur in IDU which the project code is ≥ 3-digit number, then it will display the 2 big digits of project code first, then the 2 small digits, finally the error code, e.g: L1 error occurs in no.101 IDU, then the nixie tube will display "01", "01" and "L1" circularly. Display method is the same for several IDUs with multiple errors.
	07/oC	Display circularly	No error on components of IDU. 5s later, next step starts.
08_ Confirm preheated compressor	08/U0	Display circularly	Preheat time for compressor is less than 8 hours. Display will be as in the left until the preheat time reaches 8 hours. Press main board's SW3 button to confirm manually that the preheat time has reached 8 hours. Then start next step (Note: Compressor may get damaged if it is started without 8 hours of preheat time).
	08/oC	Display circularly	Compressor has been preheated for 8 hours. 2s later, next step starts.

Description of each stage of debugging progress			
Progress	Debugging code		Code meaning and operation method
	LED		
	Code	Display status	
09_ Refrigerant judgments before startup	09/U4	Display circularly	System is lack of refrigerant and display will be as in the left. Please cut off power of IDU and ODU and check if there is leakage on pipeline. Solve the leakage problem and complement refrigerant into the unit. Then connect power and restart debugging from progress 01 (Note: Before re-charging refrigerant, unit must be power off in case system starts progress 10 automatically).
	09/oC	Display circularly	Refrigerant is normal and unit will display as in the left for 2s. Then next step starts.
10_ Status judgments of outdoor valves before startup	10/on	Display circularly	Valves of ODU are being inspected. Compressor will start operation for 2min or so and then stop. The opening and closing status of outdoor valves are as below:
	10/U6	Display circularly	Outdoor valves are not fully turned on. Press main board's SW4 button and display shows "09/OC". Then check if the gas and liquid valves of ODU are completely open. After confirmation, press the SW4 button again. Then compressor will start running for about 2min to inspect the status of valves.
	10/oC	Display circularly	Valves status is normal. Unit will display as in the left for 2s and then start next step.
12_ Confirm debugging startup	12/AP	Display circularly	Ready for units to start debugging. Press main board's SW3 button to confirm startup of debugging. 2s later, main board will display as below:
	12/AE	Display circularly	Startup is confirmed. After displaying for 2s, system will choose "15_Cooling debugging" or "16_Heating debugging" according to ambient temperature. If the project requests to add refrigerant but it is not complemented before debugging, then refrigerant can be added in this process through the L-VALVE.
15_ Cooling debugging	15/AC	Display circularly	Debugging for cooling mode. If no malfunction occurs for 50min when compressor is running, then the system is certified as normal. After shutting down the unit for 5s, the system will enter normal standby status.
	15/error code	Display circularly	Malfunction occurs when debugging for cooling mode.
16_ Heating debugging(For heat pump units only)	16/AH	Display circularly	Debugging for heating mode. If no malfunction occurs for 50min when compressor is running, then the system is certified as normal. After shutting down the unit for 5s, the system will enter normal standby status.
	16/error code	Display circularly	Malfunction occurs when debugging for heating mode.
17_ Debugging finished	oF	ON	The entire unit has finished debugging and under standby-by condition.

5.2.3 Appendix: Reference of Normal Operation Parameters

No	Debug item	Parameter name	Unit	Reference	
1	System parameters	ODU parameters	Outdoor temperature	°C	—
2			Compressor discharge temp	°C	<ul style="list-style-type: none"> ● When compressor starts, discharge temp in cool mode is within 70~105°C and at least 10°C higher than the high pressure saturation temp. ● As for temp in heat mode, it is within 65~90°C and at least 10°C higher than the high pressure saturation temp.
3			Defrosting temp	°C	<ul style="list-style-type: none"> ● In cool mode, defrosting temp is 4~10°C lower than system's high pressure value. ● In heat mode, defrosting temp is about 2°C different from system's low pressure value.
4			System high pressure	°C	<ul style="list-style-type: none"> ● In cool mode, the normal high pressure value is within 20°C~55°C. According to the change of ambient temp and system's operating capacity, the high pressure value will be 10°C~30°C higher than ambient temp. The higher ambient temp is, the smaller temp difference is. If ambient temp is 25~35°C in cool mode, system's high pressure value will be within 44~53°C. ● In heat mode, if ambient temp is above -5°C, system's high pressure value is within 40~52°C. If ambient temp is low and many IDUs are turned on, the high pressure will be lower.
5			System low pressure	°C	<ul style="list-style-type: none"> ● When ambient temp in cool mode is 25~35°C, the low pressure value is 0~8°C. ● When ambient temp in heat mode is above -5°C, the low pressure value is -15~8°C.
6			Opening angle of thermal EXV	PLS	<ul style="list-style-type: none"> ● In cool mode, the thermal electronic expansion valve remains 480PLS. ● In heat mode, the adjustable opening angle of EXV is 40~480PLS.
7			Compressor's operating freq	Hz	Changes in 10Hz~80Hz.
8			Compressor's operating current	A	When compressor works normally, the current is no more than 18.4A.
9			Compressor's IPM temp	°C	When ambient temp is below 35°C, IPM temp is lower than 80°C and the highest temp won't be above 95°C.
10			Fan motor's operating freq	Hz	Changes in 0~49Hz according to system's pressure.
11	IDU parameters	IDU ambient temp	°C	—	
12		Indoor heat exchanger's inlet temp	°C	<ul style="list-style-type: none"> ● According to ambient temp, for a same IDU in cool mode, the inlet temp will be 1°C~7°C lower than the outlet temp, and 4~9°C higher than the low pressure value. ● For a same IDU in heat mode, the inlet temp will be 10°C~20°C lower than the outlet temp. 	
13		Indoor heat exchanger's inlet temp	°C		
14		Opening angle of indoor EXV	PLS	<ul style="list-style-type: none"> ● In cool mode, the opening angle of indoor EXV varies within 70~480PLS. ● In heat mode, the opening angle of indoor EXV varies within 70~480PLS. 	
15	Communication parameters	Communication data	—	Number of IDUs detected by software is the same with the actual number. No communication error.	
16	Drainage system	—	—	Indoor unit can drain water out completely and smoothly. Condensate pipe has no backward slope of water; Water of outdoor unit can be drained completely through drainage pipe. No water drop from unit base.	
17	Others	—	—	Compressor and indoor/outdoor fan motor do not have strange noise. Unit can operate normally.	

6 Common Malfunctions and Troubleshooting



WARNING!

- ① If there is abnormal condition (e.g. unpleasant smell), turn unit off and disconnect power immediately. Then contact LENNOX authorized service center. If unit continues operation despite the abnormal condition, it may get damaged and lead to electric shock or fire hazard.
 - ② Do not repair the air conditioner by yourself. Improper maintenance may lead electric shock or fire hazard. Please contact LENNOX authorized service center for maintenance.
- (1) Please check the items below before calling for maintenance.

Problems	Causes	What to do
Unit doesn't work.	Fuse or circuit breaker is cut off.	Replace fuse or reset the circuit breaker.
	Power failure.	Restart unit when power is restored.
	Power is not connected.	Connect the power.
	Remote controller's power is not enough.	Replace new battery.
	Remote controller is out of the control range.	Control range is within 8m.
Unit runs but stops immediately.	Air inlet or air outlet of indoor and outdoor units is blocked.	Clear obstructions.
Abnormal cooling or heating.	Air inlet or air outlet of indoor and outdoor units is blocked.	Clear obstructions.
	Improper temp setting.	Adjust setting at remote controller or wired controller.
	Fan speed is set too low.	Adjust setting at remote controller or wired controller.
	Wind direction is not correct.	Adjust setting at remote controller or wired controller.
	Door or window is open.	Close the door or window.
	Direct sunshine.	Draw curtain or louver.
	Too many people in the room.	
	Too many heat resources in the room.	Reduce heat resources.
	Filter is blocked and dirty.	Clean the filter.



NOTE!

If problem cannot be solved after checking the above items, please contact LENNOX service center and describe the cases and models.

(2) Following circumstances are not malfunctions.

Malfunction		Reason
Unit doesn't run.	Unit starts up immediately after it is turned off.	Overload protection switch makes it run after a 3-min delay.
	Power is just turned on.	Standby operation lasts for about 1min.
Mist comes from the unit.	Under cooling.	Indoor air with high humidity is cooled rapidly.
Noise is emitted.	Slight cracking sound is heard when unit is just turned on.	It is the noise when electronic expansion valve is initialized.
	There is consecutive sound when cooling.	It is the sound for gas refrigerant flowing in the unit.
	There is sound when unit starts or stops.	It is the sound when gas refrigerant stops flowing.
	There is slight and consecutive sound when unit is running or after running.	This is the sound of drainage operation.
	Cracking sound is heard when unit is running or after running.	This is the sound caused by the expansion of panel and other parts of the unit due to temperature change.
Unit blows out dust.	Unit starts up after not operating for a long time.	Dust in indoor unit is blown out.
Unit emits odor.	Under operation.	Unit absorbs the room odor and then blows it out.

7 Error Indication

Inquiry method of error indication: combine division symbol and content symbol to check the corresponding error.

Indoor:

Error Code	Content	Error Code	Content
L0	Malfunction of IDU (uniform)	d1	Indoor PCB is poor
L1	Protection of indoor fan	d3	Malfunction of ambient temperature sensor
L2	Auxiliary heating protection	d4	Malfunction of entry-tube temperature sensor
L3	Water-full protection	d5	Malfunction of middle temperature sensor
L4	Abnormal power supply for wired controller	d6	Malfunction of exit-tube temperature sensor
L5	Freeze prevention protection	d7	Malfunction of humidity sensor
L6	Mode shock	d9	Malfunction of jumper cap
L7	No main IDU	dA	Web address of IDU is abnormal
L8	Power supply is insufficient	dH	PCB of wired controller is abnormal
L9	1-to-more: number of IDU is inconsistent	dC	Setting capacity of DIP switch code is abnormal
LA	t1-to-more: IDU series is inconsistent	dL	Malfunction of air outlet temperature sensor
LH	Alarm due to bad air quality (Fresh air unit)	dE	Malfunction of indoor CO ₂ sensor
LC	IDU is not matching with outdoor unit	db	Debugging status

Outdoor:

Error Code	Content	Error Code	Content
E0	Malfunction of ODU (uniform)	F0	Main board of ODU is poor
E1	High-pressure protection	F1	Malfunction of high-pressure sensor
E2	Discharge low-temperature protection	F3	Malfunction of low-pressure sensor
E3	Low-pressure protection	F5	Malfunction of discharge temperature sensor of compressor 1

Error Code	Content	Error Code	Content
E4	High discharge temperature protection of compressor	FP	Malfunction of DC motor
E5	High discharge temperature protection of compressor 1	b1	Malfunction of outdoor ambient temperature sensor
EC	Drop protection of discharge temperature sensor of compressor 1	b2	Malfunction of defrosting temperature sensor 1
J1	Over-current protection of compressor 1	b4	Malfunction of liquid temperature sensor of sub-cooler
J7	Gas-mixing protection of 4-way valve	b5	Malfunction of gas temperature sensor of sub-cooler
J8	High pressure ratio protection of system	b6	Malfunction of inlet tube temperature sensor of vapor liquid separator
J9	Low pressure ratio protection of system	b7	Malfunction of exit tube temperature sensor of vapor liquid separator
JA	Protection because of abnormal pressure	b9	Malfunction of gas temperature sensor of heat exchanger
JL	Protection because high pressure is too low	bH	Clock of system is abnormal
P0	malfunction of driving board of compressor (uniform)	H0	Malfunction of driving board of fan (uniform)
P1	Driving board of compressor operates abnormally (uniform)	H1	Driving board of fan operates abnormally (uniform)
P2	Voltage protection of driving board power of compressor (uniform)	H2	Voltage protection of driving board power of fan (uniform)
P3	Reset protection of driving module of compressor	H3	Reset protection of driving module of fan
P4	Drive PFC protection of compressor	H4	Drive PFC protection of fan
P5	Over-current protection of inverter compressor	H5	Over-current protection of inverter fan
P6	Drive IPM module protection of compressor	H6	Drive IPM module protection of fan
P7	Malfunction of drive temperature sensor of compressor	H7	Malfunction of drive temperature sensor of fan
P8	Drive IPM high temperature protection of compressor	H8	Drive IPM high temperature protection of fan
P9	Desynchronizing protection of inverter compressor	H9	Desynchronizing protection of inverter fan
PH	High-voltage protection of compressor's drive DC bus bar	HH	High-voltage protection of fan's drive DC bus bar
PC	Malfunction of current detection circuit drive of compressor	HC	Malfunction of current detection circuit of fan drive
PL	Low voltage protection for DC bus bar of drive of compressor	HL	Low voltage protection of bus bar of fan drive
PE	Phase-lacking of inverter compressor	HE	Phase-lacking of inverter fan
PF	Malfunction of charging loop of driven of compressor	HF	Malfunction of charging loop of fan drive
PJ	Failure startup of inverter compressor	HJ	Failure startup of inverter fan
PP	AC current protection of inverter compressor	HP	AC current protection of inverter fan
Ed	Low temperature protection for drive module		

Debugging:

Error Code	Content	Error Code	Content
U0	Preheat time of compressor is insufficient	C4	Malfunction of lack of IDU

Error Code	Content	Error Code	Content
U2	Wrong setting of ODU's capacity code/jumper cap	C5	Alarm because project code of IDU is inconsistent
U4	Refrigerant-lacking protection	C8	Emergency status of compressor
U5	Wrong address for driving board of compressor	C9	Emergency status of fan
U6	Alarm because valve is abnormal	CH	Rated capacity is too high
U8	Malfunction of pipeline for IDU	CC	Malfunction of lack of main control unit
U9	Malfunction of pipeline for ODU	CL	Rated capacity is too low
UC	Setting of main IDU is successful	CF	Malfunction of multiple main control units
UL	Wrong button-dial	CJ	Address DIP switch code of system is shocking
UE	Charging of refrigerant is invalid	CP	Malfunction of multiple wired controller
C0	Communication malfunction between IDU, ODU and IDU's wired controller	CU	Communication malfunction between IDU and the receiving lamp plate
C2	Communication malfunction between main control and inverter compressor driver	Cb	Overflow distribution of IP address
C3	Communication malfunction between main control and inverter fan driver		

Status:

Error Code	Content	Error Code	Content
A0	Unit waiting for debugging	AP	Debugging confirmation when starting up the unit
A1	Inquiry of compressor operation parameters	AU	Long-distance emergency stop
A2	Refrigerant recovery operation of after-sales	Ab	Emergency stop of operation
A3	Defrosting	Ad	Limit operation
A4	Oil-return	n0	SE operation setting of system
A6	Heat pump function setting	n1	Setting of defrosting cycle K1
A7	Quiet mode setting	n2	Setting of upper limit of IDU/ODU capacity distribution ratio
A8	Vacuum pump mode	n4	Limit setting for max. capacity/output capacity
A9	IPLV test	n6	Inquiry of malfunction
AA	EU AA level EER test mode	n7	Inquiry of parameters
AH	Heating	n8	Inquiry of project code of IDU
AC	Cooling	nA	Heat pump unit
AL	Charge refrigerant automatically	nH	Heating only unit
AE	Charge refrigerant manually	nC	Cooling only unit
AF	Fan	nE	Negative code
AJ	Cleaning reminding of filter	nF	Fan model

8 Maintenance and Care

Regular check, maintenance and care can extend unit's service life. Please have specialized person in charge of the management of air conditioners.

8.1 Outdoor Heat Exchanger

Outdoor heat exchanger shall be cleaned regularly, which is at least once every two months. You can use a dust catcher with nylon brush to clean away the dust on the heat exchanger. If compressed

air source is available, it also can be used to clean the heat exchanger. Do not clean it with water.

8.2 Drain Pipe

Please check regularly whether drain pipe is blocked or not. Make sure condensate can be drained out smoothly.

8.3 Notice before Seasonal Use

- (1) Check whether air inlets and air outlets of indoor and outdoor units are blocked.
- (2) Check whether ground connection is reliable or not.
- (3) Check whether batteries in the remote controller are replaced or no.
- (4) Check whether air filter is properly installed.
- (5) If unit starts up after not operating for a long time, it should be power on 8 hours before operation starts so as to preheat the outdoor compressor.
- (6) Check whether outdoor unit is securely installed. If there is any problem, please contact LENNOX authorized service center.

8.4 Maintenance after Seasonal Use

- (1) Disconnect power of the entire system.
- (2) Clean the air filter and outer case of indoor and outdoor units.
- (3) Clean away the dust and obstacles on indoor and outdoor units.
- (4) If outdoor unit has rust, please apply some paint to it so as to prevent the rust from growing.

8.5 Parts Replacement

Parts and components can be obtained from nearby LENNOX office or LENNOX distributor.



When you are conducting air tightness test and leakage test, do not mix oxygen, C_2H_2 or other dangerous gas into the refrigerant circuit. Otherwise, it may lead to danger. Use nitrogen or refrigerant to conduct the tests.

9 After-sales Service

If there's quality defect or other problems in the product, please contact LENNOX local after-sales service department for help.

Warranty must be based on the following conditions:

- (1) Product's initial startup must be performed by professional technicians from LENNOX service center or persons assigned by LENNOX.
- (2) Only GLENNOX spare parts are used.
- (3) All instructions of unit operation and maintenance in this manual must be strictly followed according to set period and set frequency.
- (4) Any breach of the above conditions will disable the warranty.



Contact us at +1-305-718-2901
lennoxglobalhvac@lennoxintl.com

© 2019 Lennox Industries Inc.
For a complete list of the registered and common law trademarks
owned by Lennox Industries Inc., please visit www.lennox.com

